



5.0 Speaker Mount User's Guide and Installation Manual

Before You Start Read This Section Carefully

To use the 5.0 Speaker Mount Kit, your speaker must meet the following criteria:

- This mount is intended for mini speakers that weigh up to 5lbs (2.3kg) and have a 6mm threaded insert. (See illustration)
- This mount will only fit and securely mount speakers with 6mm pre-threaded inserts. If you are unsure about the insert, please contact the speaker manufacturer.

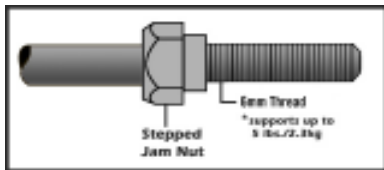

Note: Use the supplied screws and anchors. Your 5.0 Mount is supplied with oversize surface mounting screws and anchors. The generous size of these fasteners provides an extra margin of safety for your installation. **Do not use substitutes.**

Your speaker must have a factory-installed 6mm threaded insert. We have found that most of the factory inserts installed for mounting are strong enough to safely support the speaker. However, some inserts located on the top, bottom, or sides of the speaker are designed to be used in pairs for attaching a “U-shaped” bracket to the speaker. When one of these two inserts is used alone it may not have adequate pullout strength to support the weight for the speaker in some cases. **If you have any questions regarding the use of the inserts in your speaker, consult your dealer or contact the speaker manufacturer directly.**

KIT COMPONENTS & HOW THEY WORK TOGETHER:

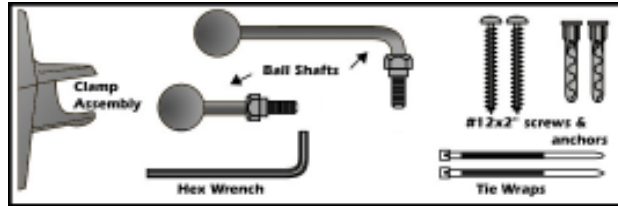

The ball shaft-threads into the speaker. The clamp assembly-Consists of the clamp plate and jaw. It mounts to the wall, ceiling or a shelf. The clamp surrounds the ball. The mounting angle may be adjusted by simply loosening the clamp assembly tension screw.

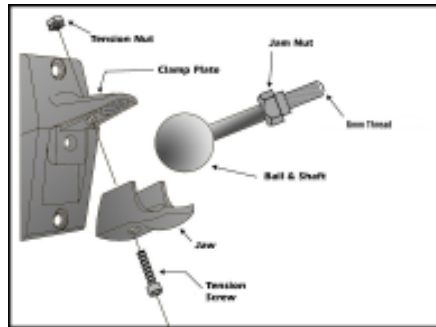

Mounting Options

Before you begin, decide which mounting option and ball shaft are appropriate for your speaker.



Tools Required

You will need at least these tools for the installation

- 5/32" hex wrench (supplied)
- An electric drill
- Drill bits: 1/4" (for drywall installation) or 5/16" (for wood and masonry surfaces)
- 7/16"(11mm) open wrench or small crescent wrench
- Phillips screwdriver, medium size (or electric drill with Phillips drive bit)
- Wire cutters
- Hammer

Step 1: Attaching the Ball Shaft to the Speaker

- Insert the ball shaft appropriate to the mounting option you have selected (refer to the mounting options above).
- Rotate the ball shaft several turns until it is fully threaded into the female insert on the speaker. When you “hit bottom”, back out the ball shaft approximately one quarter turn (see Fig. E).
- Using the 7/16" (11mm) open wrench, tighten the jam nut.

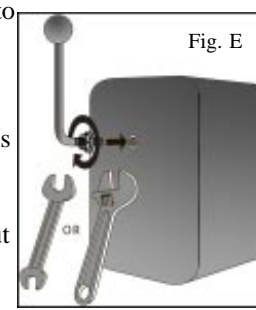

CAUTION: DO NOT OVER-TIGHTEN. When the ball shaft resists moderate rotational force and forms a solid joint with the speaker, stop tightening.

Step 2: Positioning the Clamp Assembly

2.1 Wall mounting

Orient the clamp assembly vertically—the OmniMount logo should be facing toward the ceiling, the tension screw head faces toward the floor (see fig. G or H)

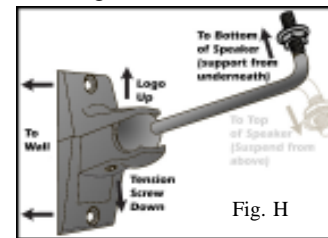
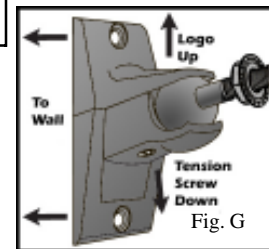

CAUTION: It may be necessary to check that the surface preparation and the fasteners will not interfere with electrical wiring, plumbing, etc., behind your mounting surface (wall, ceiling, floor).

2.2 Ceiling or shelf mounting orientation

The clamp assembly should be oriented so that the clamp plate and OmniMount logo face the same direction as the front of the speaker you are mounting.

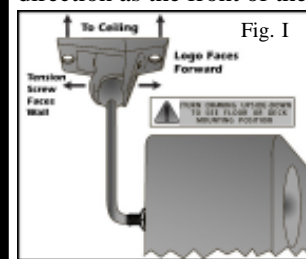

The jaw and the tension screw will face in the opposite direction (toward the wall).(see fig I or J)

2.2 Ceiling or shelf mounting orientation

Now, position the clamp assembly on the wall, ceiling or shelf at the mounting location you have selected.

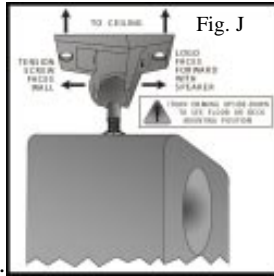

Using the clamp plate as a template, accurately mark the two hole locations with a pencil. Remove the clamp plate before drilling holes.

STEP 3: PREPARING THE MOUNTING SURFACE AND ATTACHING THE CLAMP ASSEMBLY

Using the clamp plate as a template, mark the two holes with a pencil. Remove the clamp plate before drilling into your mounting surface.

CAUTION: It may be necessary to check that the surface preparation and the fasteners will not interfere with electrical wiring, plumbing, etc., behind the mounting surface (wall, ceiling, or floor).

Your OmniMount Speaker Mount is designed to be mounted on a variety of wall and ceiling constructions. Please follow all safety precautions listed here before installing the Clamp and Jaw Assembly.

CAUTION: Drilling holes into masonry or concrete material requires the use of a carbide tipped 5/16" (8mm) diameter masonry drill and/or hammer drill. Always wear eye protection.

Mounting Onto Solid Wood

- Insert a 5/16" (8mm) diameter drill bit (not provided). Set depth of drill at a minimum 2" (63.5mm) protruding from the end of your drill.
- Center the drill on the marked hole locations and carefully drill the two holes to the minimum 2" (63.5mm) depth.

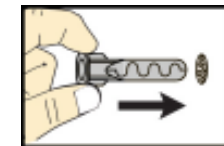

- Insert the two anchors fully until the flange is flush against the mounting surface (Fig. K).

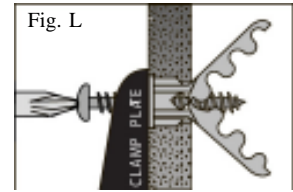

- Position the clamp assembly over the anchors. (Fig. L)

Step 5:
ADJUSTING THE POSITION OF THE SPEAKER AND TIGHTENING THE CLAMP ASSEMBLY

- Pick up the vice grip pliers, regular pliers, or small crescents wrench and use one of these tools to assist in tightening the tension screw. Tighten in ½ turn increments until the speaker is firmly held in place.
- Insert the hex key into the tension screw head and tighten (see Fig. O)
- If the speaker angle must be changed, do not attempt to move the speaker without first loosening the tension screw. **Reposition, then tighten the tension screw further until the speaker is held firmly in place.**



Caution: Tightest is not always the best! Over tightening fasteners can weaken the installation. Make sure the connection is extremely solid and then stop tightening.

- If rotational adjustment of the mounted speaker is required, the jam nut must first be loosened, the speaker rotated, and the jam nut tightened again. Use the 7/16" (11mm) open wrench or a small adjustable crescent wrench for this procedure.

Caution: If the speaker loses its position, do not attempt to move the speaker without first loosening the tension screw. Reposition, then tighten the tension screw further until the speaker is held firmly in place.

Step 6:
Securing the Speaker Wire to the Ball Shaft

- You can help to enhance the appearance of the installation with the two small tie wraps that have been provided in your kit:



- Position the wire on the ball shaft. Wrap one of the tie wraps around both the ball shaft and wire. Repeat this step for the second tie wrap.

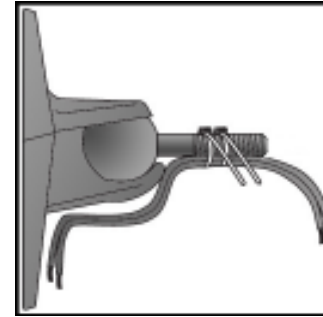

- Loop the open end of the tie wrap into the slot in the other end. Pull tie wrap closed. Repeat this step for the second tie wrap.
- Using a small pair of wire cutters, snip the extra lengths of the tie wrap off-as close as possible to the wrap "buckle."

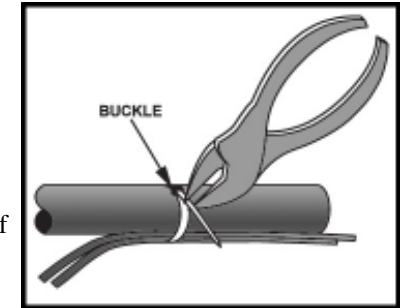

CONGRATULATIONS!
YOUR INSTALLATION IS NOW COMPLETE.

Note: The following is made in lieu of all warranties expressed or implied. The Manufacturer's only obligation shall be to replace parts of this product proved to be defective within two years of the date of purchase. We are aware that this mounting assembly may be used for purposes and in ways other than those for which it had been designed and manufactured. The Manufacturer, Distributor, Retail and their respective agents cannot be held responsible or liable for injuries or property damage—direct, indirect, or consequential—arising out of the use, or inability to use this product safely and properly.

Note: Every effort has been made to provide accurate and error-free assembly and installation information. Omnimount Systems disclaims liability for any difficulties arising from the interpretation of information contained in these instructions.



OMNIMOUNT SYSTEMS, INC.
8201 South 48th Street
Phoenix, AZ 85044-5355
Voice: 480-829-8000
Fax: 480-756-9000
Email: hdqrs@omnimount.com
Web: www.omnimount.com